

# CNC

## High pressure machine vise

CNC high pressure vise with constant length for high precision workpieces on machining centres, for horizontal and vertical use.

- > Strong body of spheroidal graphite iron GJS-600
- > Guide rails hardened and precision ground
- > Longitudinal and lateral grooves 20 H7 for aligning on the machine tables well as 2 locating holes  $\varnothing$  25 H7 for mounting on zero point clamping systems
- > Precise, fine clamping force pre-selection
- > Connection thread on both sides for side stop
- > Step jaws for wide clamping ranges
- > Quick release system for optional step ledges
- > Mechanical-hydraulic spindle fully encapsulated, low-wear and maintenance-free
- > Threaded holes for screwing on facing jaws (accessories)
- > Spindle with bayonet mounting for quick removal
- > Possibility of direct clamping with operating key provided
- > Stable exchangeable cover plates

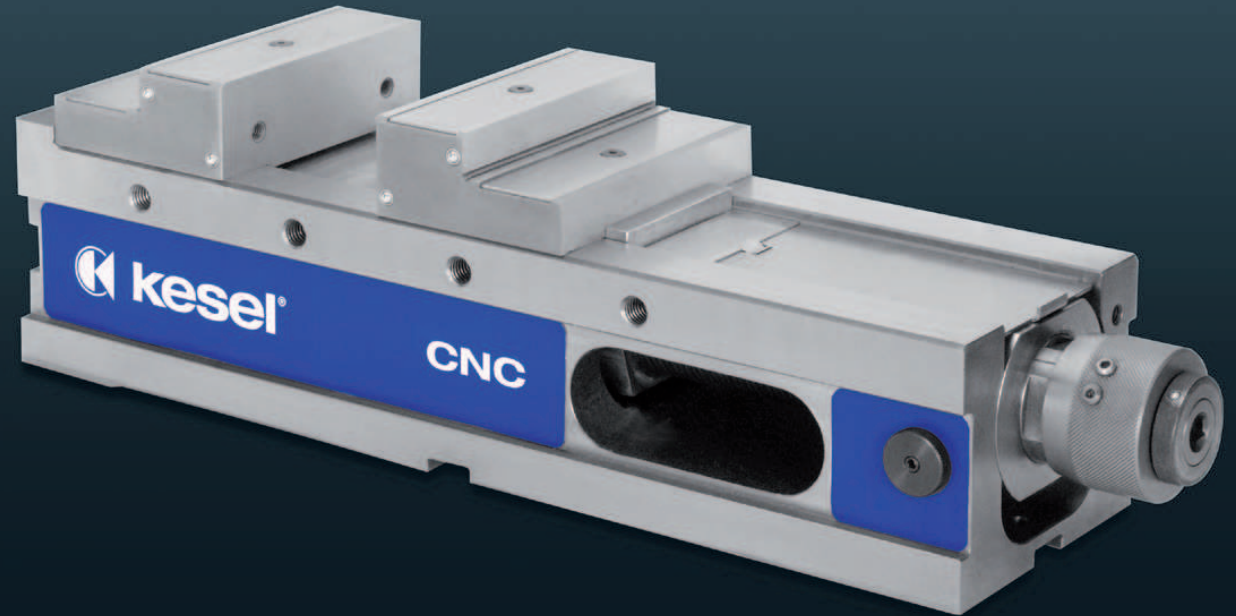

### Scope of delivery:

4 clamping claws, 1 manual crank, 1 operating key

### Variants:

#### Horizontal range of application

> The vise is clamped on the base plate

#### All-round range of application

> The vise can be fitted on the front of the base plate for vertical attachments, or on its sides

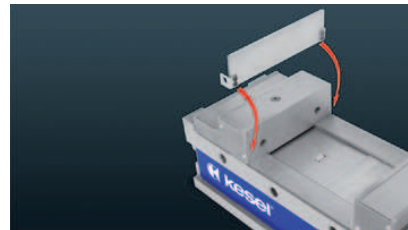

#### Step ledge quick release system

- > Step ledges are simply "clicked" in by hand, with no need for tools
- > No penetration of chips beneath the step ledge
- > Secure and stable hold, also with the use of compressed air
- > Available in a range of heights (accessories)

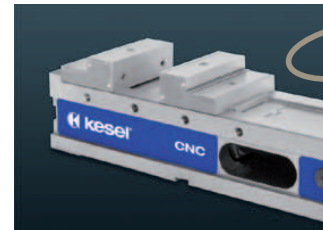

#### Jaw quick release system

- > Quick rotation or change of the serial top jaws (it is only necessary to turn and open 2 fastening screws)
- > Quick replacement of custom jaws produced in-house

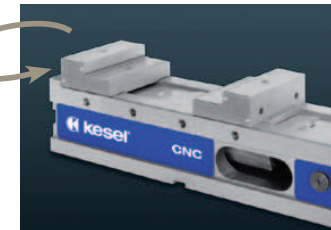

#### Angle drive

- > Operation via table with pre-screwed angle drive (accessory)
- > Optimum accessibility for force adjustment

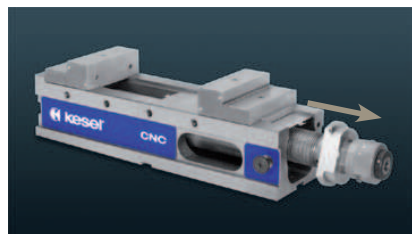

#### Quick removal of the spindle unit possible:

- > Allowing vise body to be easily fitted to machine table
- > Optimum cleaning possibilities



#### CNC pendulum jaw (accessories)

- > With corrugation and spring plate
- > 360° pivoting
- > For non-parallel workpieces

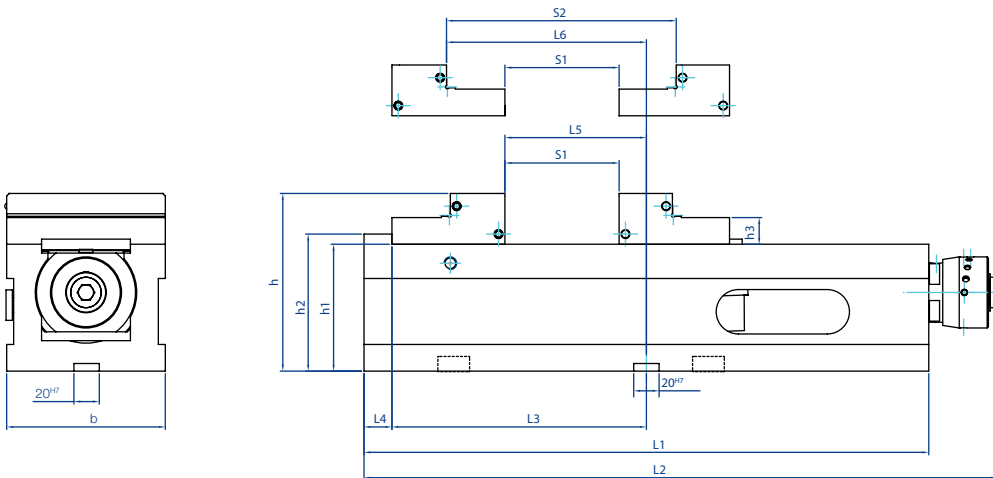
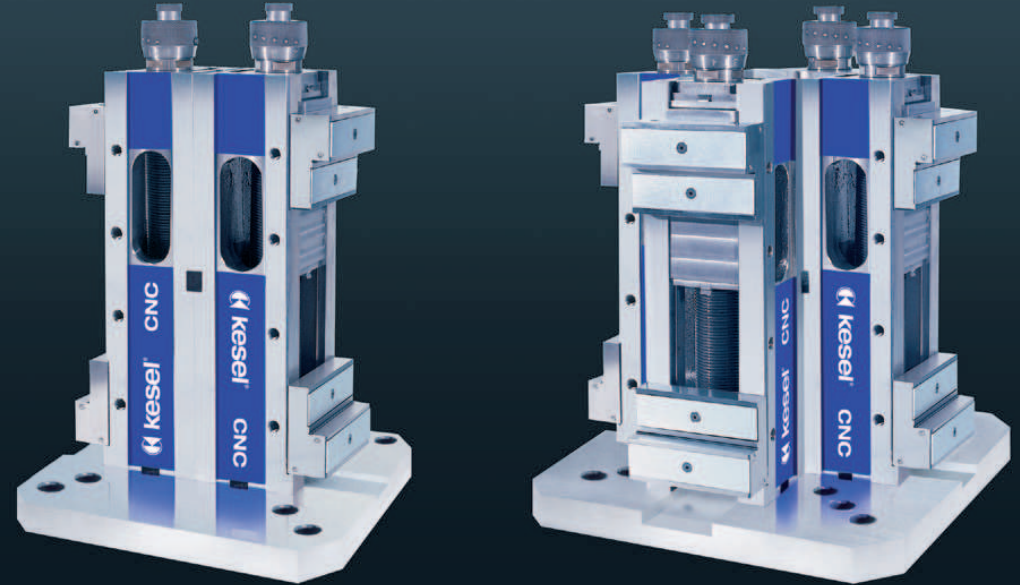
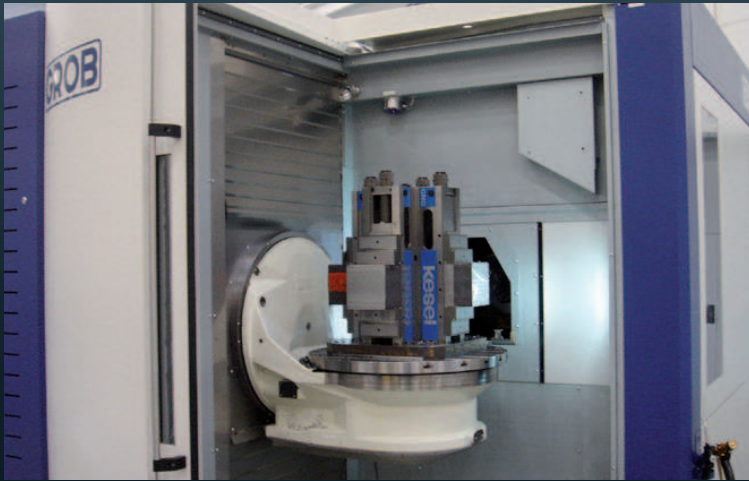

Size b	Order number		Body width b	Clamping range		Clamping force in kN	Weight in kg
	for horizontal use	can be clamped on 3 planes		Stufe 1	Stufe 2		
125	04.25.160.050.9	04.25.160.001.9	126	0 - 210	91 - 301	40	34
160	04.25.260.050.9	04.25.260.001.9	162	0 - 289	113 - 402	60	60

  

h	h1 ±0,01	h2	h3	L1	L2	L3	L4	L5	L6	L7	L8
140	100	108	22	445	499	200,5	22	111,5	157,5	150	50
165	115	123	30	580	655	288,5	25	176,5	233,5	-	-

### Attachments

We offer you the optimum attachment for your special requirements

- > The vertical arrangement of individual vises enables optimum accessibility of the machine spindle
- > In comparison to the single-part monoblock construction, star set-ups can be flexibly aligned with the respective needs and then dismantled into the individual vises again as necessary
- > Flexible base plates fit with your machine

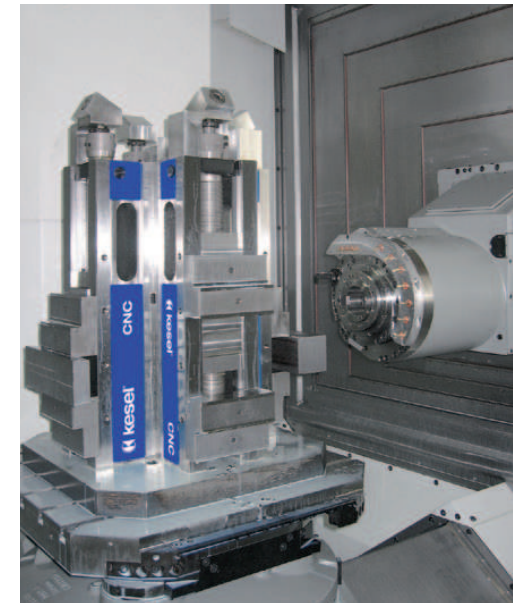

CNC accessories

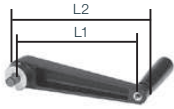

**Manual crank standard version** with snap ring to prevent it falling out due to machine vibrations

Size	Order no.	L1	L2	Width	Allen
160-200	03.15.203.002.4	160	190	127	12 mm



**Manual crank in shortened version** for use in place of the standard manual crank, if the throughput height to the machine table is too small

Size	Order no.	Length	Width	Allen
125-160	03.15.103.001.4	110	90	12 mm
200	03.15.303.001.4	130	125	12 mm

**Crank extension**

without foto

For Size	Order no.	Length	Allen
125	03.15.203.001.9	90 mm	12 mm

**Smooth clamping jaw hardened**, ground, standard equipment  
**Smooth clamping jaw soft (1.2842)**, milled, for the fabrication of moulding jaws

**Clamping jaw with linear grooves** for firmly gripping the workpieces

Size	Order no.	Height	Thick-ness
<b>Smooth clamping jaw hardened</b>			
125	01.25.152.014.4	39,2	12
160	01.10.201.004.4	49,2	16

Size	Order no.	Height	Thick-ness
<b>Smooth clamping jaw soft</b>			
125	01.11.105.002.5	39,2	12
160	01.11.205.002.4	49,2	16

Size	Order no.	Height	Thick-ness
<b>Clamping jaw with linear grooves</b>			
125	01.11.105.001.5	39,2	12
160	01.11.205.001.5	49,2	16

**Smooth clamping jaw** with step, hardened and ground, for saving clamping supports

Size	Order no.	Step	Thick-ness	Height
125	01.11.105.003.5	3 x 6	12	39,2
125	01.11.105.008.5	5 x 10	12	39,2
160	01.11.205.003.4	5 x 8	16	49,2

**Clamping jaw with corrugation** hardened and ground

Size	Order no.	Height	Thick-ness	Gripper Order no.	Thread
125	01.26.160.035.3	40	12	01.26.160.048.4	M10
160	01.26.260.030.3	50	16	01.26.260.080	M12

CNC accessories



**Grip clamping jaw**, hardened, with step

Size	Order no.	Height	Thickness	Step
125	01.25.150.0002	40	12	3x3
160	01.25.260.0004	50	16	3x5



**Prism jaws with horizontal prism 120°**  
hardened and ground

Size l	Order no.	Height	Thick-ness	Clamping diameter	
				with 1 jaw	with 2 jaw
125	01.11.105.005.4	39,2	20	ø 9-50	ø 14-50



**Prism jaw with horizontal and vertical prism 90°**  
hardened and ground

Size l	Order no.	Height	Thick-ness	Clamping diameter	
				with 1 jaw	with 2 jaw
125	01.11.105.004.4	39,2	28	ø 15-42	ø 24-42
160	01.11.205.004.3	49,2	32	ø 18-50	ø 28-50

**Pendulum jaws** with smooth slide, hardened and ground, for clamping conical workpieces

Size	Order no.	Height	Thickness
125	04.13.125.150.9	39,2	43
160	04.13.160.150.9	49,2	52

**Pull-down jaws** smooth, the workpiece is hold securely, with a deep drawing effect

Size	Order no.	Height	Thickness
125	04.13.125.200.9	39,2	25
160	04.13.160.200.9	49,2	28

**Pull-down jaws for raw parts** with inset spring plate for clamping raw parts. The spring plate establish a secure hold and deep drawing effect

Size	Order no.	Height	Thickness
125	04.13.125.250.9	40	21
160	04.13.160.250.9	50	24

**Multi-jaws** flexible in use for grip application, as well as pendulum jaws and support elements

Size	Fix Order no.	Mobile Order no.	Length	Width	Height
125	04.25.160.1000	04.25.160.1001	170	105	25
160	04.25.260.1000	04.25.260.1001	200	115	25



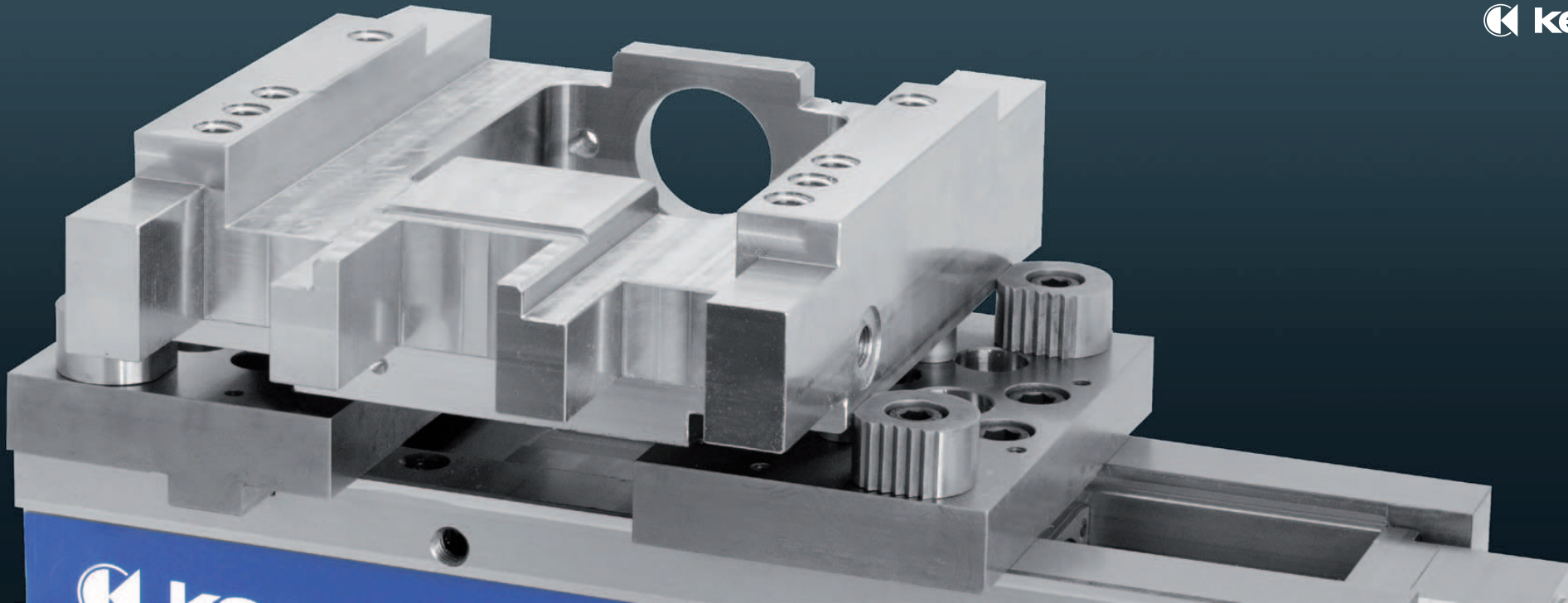

CNC accessories



**Pendulum jaw** fits to multi-jaw mobile for clamping non-parallel workpieces, cast parts and shaped workpieces  
Scope of delivery: with 2 x hard metal grip insert

For size	Order no.	Length	Width	Height
125	04.25.150.052	156	65	20
160	04.25.265.1002	196	76	23



Step ledges

For size	Order no.	Height	Thickness
125	03.25.160.022.9	13	3
125	03.25.160.023.9	22	3
125	03.25.160.024.9	35	3
125	03.26.160.002.9	39	3
125	04.25.150.060	35	3
125	04.25.150.061	15	3
160	03.25.260.022.9	14	3
160	03.25.260.023.9	30	3
160	03.25.260.024.9	44	3
160	03.26.260.0001	49	3



**Universal top jaws with angle adjustment**  
possibility hardened and ground

Size	Order no.	Height	Thickness
125	04.13.125.400.9	42	10
160	04.13.160.400.9	52	10



**Workpiece stop** adjustable

For size	Order no.	Thread
125	03.11.008.001.4	M 12



**Pendulum jaws CNC** with corrugation and spring plate,  
360° pivoting

Size	Order no.	Height	Thickness
125	03.26.160.005.3	40	80
160	03.26.260.005.3	50	104